

Condensateurs céramique de puissance refroidis par eau- Type I

Type HWS

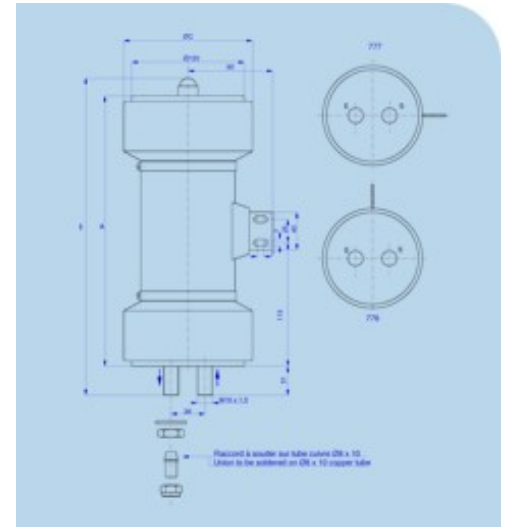

Caractéristiques

CARACTERISTIQUES ELECTRIQUES									DIMENSIONS		
Références	Capacité pF ± 10%	ϵr	Tension		Fréquences		Puissance réactive nominale (kVar)	Intensité nominale efficace (A)	A (+7mm)	B (+7mm)	C (+1mm)
			Un (kVc)	Utest (kVdc)	F1 (Mhz)	F2 (Mhz)					
40606 776/777	2500 pF	17	25	35,5	0,81	1,95	4000 kVar	350 A	279	330	137
40595 776/777	5000 pF	75	25	35,5	0,41	0,97	4000 kVar	350 A	266	317	137
40572 776/777	6000 pF	75	25	35,5	0,34	0,81	4000 kVar	350 A	266	317	137
40492 776/777	7500 pF	75	22,5	32	0,34	0,65	4000 kVar	350 A	270	321	137
40602 776/777	7500 pF	75	25	35,5	0,27	0,65	4000 kVar	350 A	286	317	137
40578 776/777	8800 pF	75	16,5	23	0,53	0,55	4000 kVar	350 A	266	317	137
40490 776/777	10000 pF	75	14	20	0,55	0,57	3400 kVar	350 A	270	321	137
40601 776/777	10000 pF	75	20	28,5	0,32	0,49	4000 kVar	350 A	286	337	137
40605 776/777	12000 pF	75	17	24	0,37	0,41	4000 kVar	350 A	286	337	137

Plan

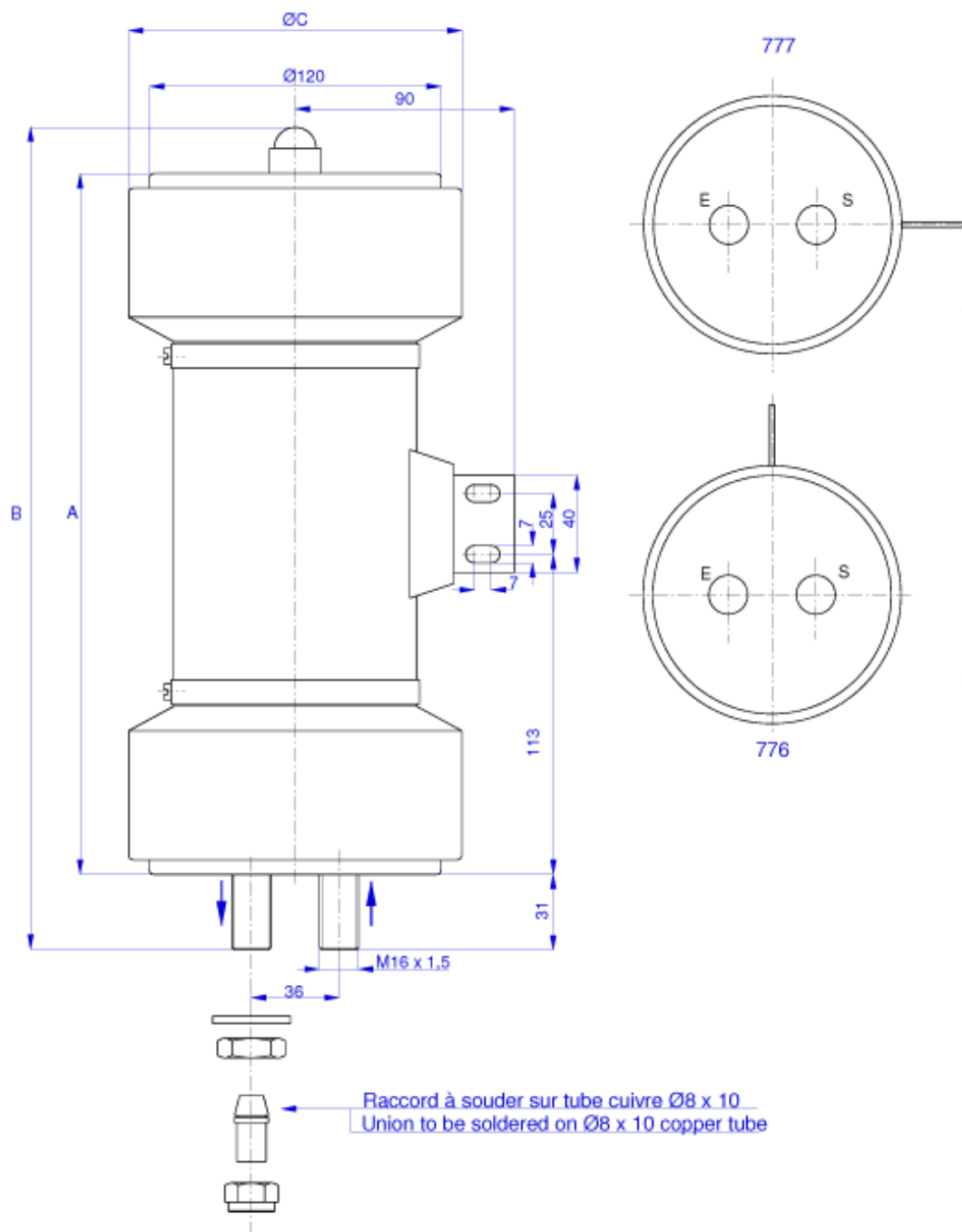

Courbes

40 606 776/77

2500 pF

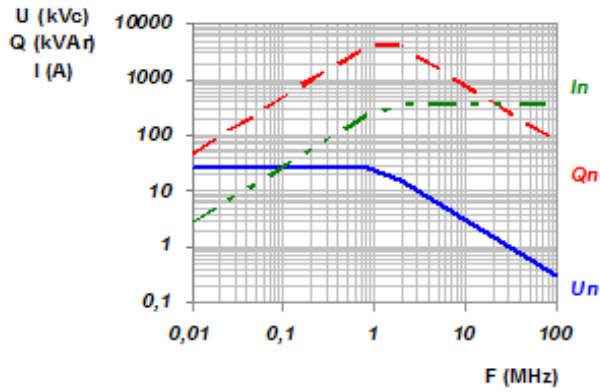

40 595 776/77

5000 pF

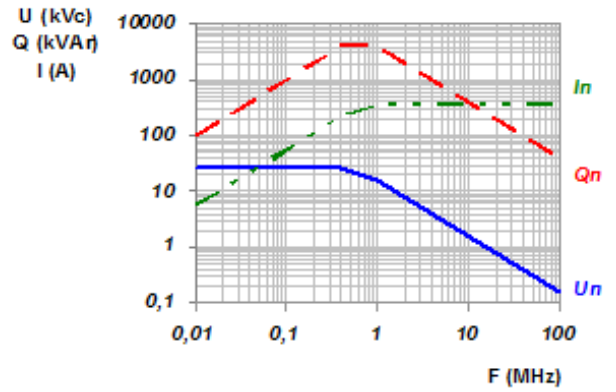

40 572 776/77

6000 pF

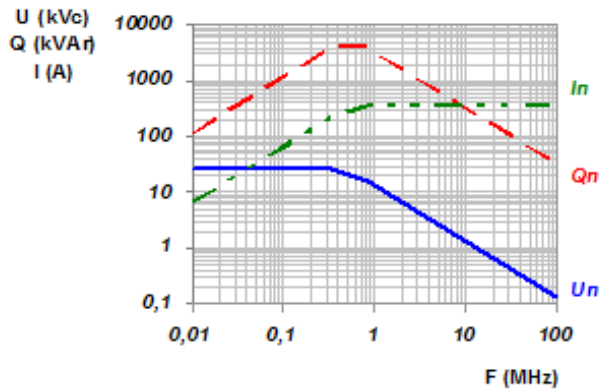

40 492 776/77

7500 pF

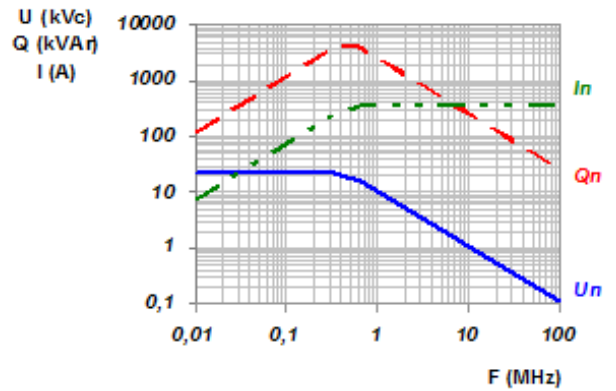

40 602 776/77

7500 pF

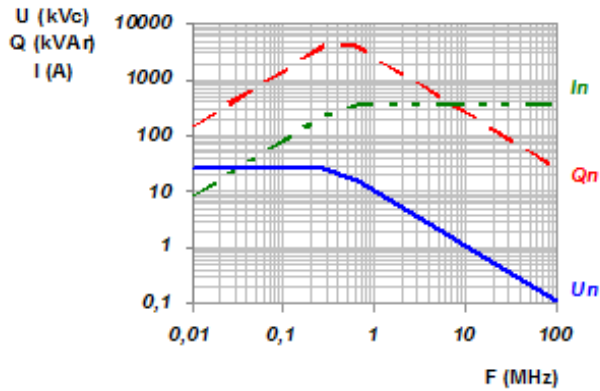

40 578 776/77

8800 pF

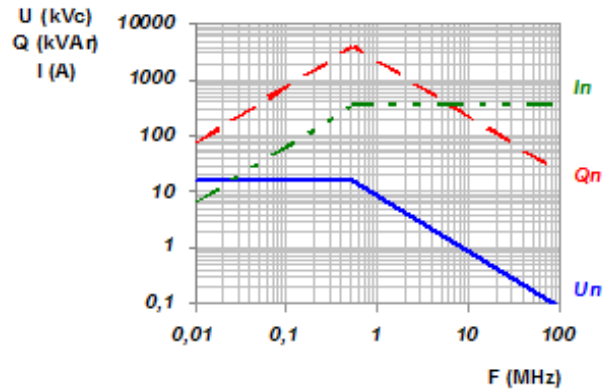

40 490 776/77

10000
pF

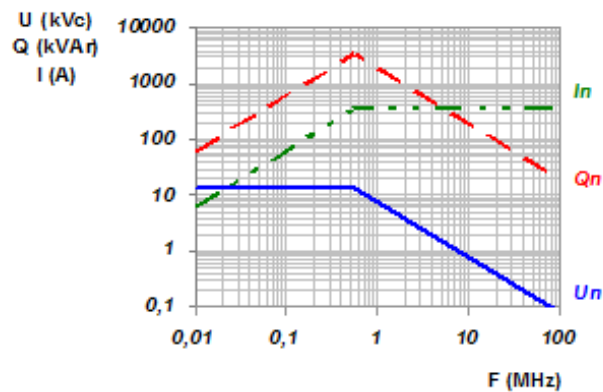

40 601 776/77

10000
pF

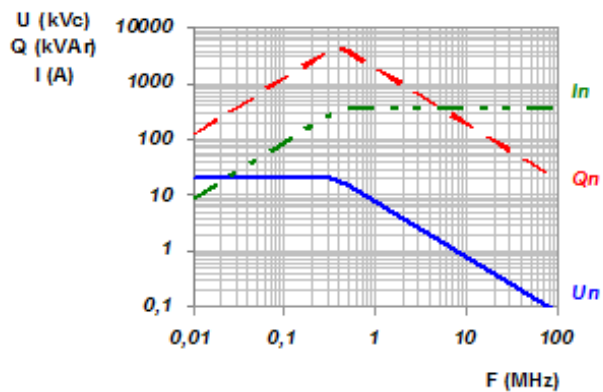

40 605 776/77

12000
pF

